

# Brushless Servo Motors

## Quantum QB56 Series Housed Brushless Servo Motors

*NEMA Size 56 High Power Density, Sinusoidal BEMF*

Allied Motion's **Quantum (QB) housed brushless servo motors** are designed for use in precision servo applications that require a standard NEMA size 17, 23, 34 or 56 frame motor.

The QB056 series are eight-pole motors with 3-phase delta-wound stators that conform to NEMA size 56 mounting standards. Rated torques range from 2.8 up to 11.1 Nm, and rated power extends from 957 up to 2551 W. Winding voltage choices are 40, 130 and 300 V.

The QB series are electromechanically optimized for high output power, high torque density, and low cogging torque. Their high power density ratio allows a smaller size motor to be used in many applications, saving space and weight.

Quantum motors are also available as frameless versions for direct machine integration.

### Features & Benefits

- NEMA 56 frame size with four stack lengths
- Rated torque from 2.8 up to 11.1 Nm; rated power from 957 up to 2551 W
- Standard winding voltage ratings of 40, 130 and 300 V
- Rare-earth NdFeB magnets maximize torque production
- Integrated Hall commutation sensors
- Computer optimized design for maximum power and torque density ensures the most compact and efficient design possible

### Options

- Encoder and resolver feedback options for compatibility with servo drives and motion controllers
- Sealed versions up to IP65 for operation in harsh environments
- Custom winding voltages and other customizations to meet specific application requirements



- NEMA size 56 high performance brushless servo motor
- Rated power from 957 up to 2551 W and rated torque of from 2.8 up to 11.1 Nm
- Standard winding voltages of 40, 130 and 300 V

## DIMENSIONS

MODEL	"X" MAX.
QB05600	4.84 (123)
QB05601	5.84 (148.3)
QB05602	6.84 (173.7)
QB05603	7.84 (199)

LEADWIRE - TEFLON COATED  
TYPE "E" PER MIL-W-16878/4  
12" MINIMUM LENGTH  
A) MOTOR: 12 AWG RED(A),WHT(B),BLK(C)  
B) SENSOR 24 AWG BLU(+),BRN(A),DRG(B)  
YEL(C),GRN(GRD)

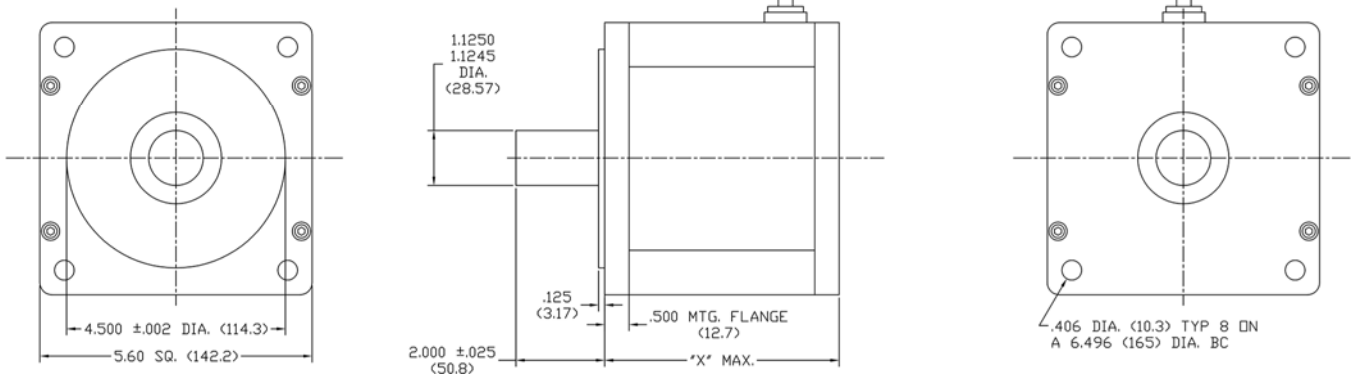

in (mm)

# Brushless Servo Motors

## Quantum NEMA 56 Series Housed Brushless Servo Motors

### SPECIFICATIONS

Model No.		QB05600			QB05601		
Winding Voltage	V	40	130	300	40	130	300
Stall Torque (continuous) <sup>(1)</sup>	oz-in	599	597	601	1145	1133	1173
	Nm	4.2	4.2	4.2	8.1	8.0	8.3
Rated Power <sup>(1)</sup>	W	957	1252	1279	1520	1601	1669
Rated Torque <sup>(1)</sup>	oz-in	513	395	397	857	753	803
	Nm	3.6	2.8	2.8	6.0	5.3	5.7
Rated Speed	RPM	2521	4289	4360	2400	2875	2810
Peak Torque	oz-in	4258	4290	4255	8514	8474	8436
	Nm	30.1	30.3	30.0	60.1	59.8	59.6
Rated Phase Current	A	37.8	13.7	6.8	58.1	21.1	10.3
Peak Current	A	227	123	63	411	205	94
Torque Constant (±10%)	oz-in/A	18.8	34.9	67.6	20.7	41.3	89.7
	Nm/A	0.133	0.247	0.477	0.146	0.292	0.633
Voltage Constant (±10%)	V/kRPM	13.9	25.8	50.0	15.3	30.5	66.3
	V/rad/s	0.133	0.247	0.477	0.146	0.292	0.633
Cogging Torque (max.)	oz-in	11.0			19.0		
	Nm	0.078			0.134		
Rotor Inertia	oz-in-s <sup>2</sup>	0.09			0.16		
	kg-m <sup>2</sup>	6.33E-04			1.15E-03		
Motor Constant	oz-in/√W	80	80	80	126	126	129
	Nm/√W	0.57	0.56	0.57	0.89	0.89	0.91
Elect. Time Constant	ms	5.21	5.22	5.25	5.37	5.75	6.82
Mech. Time Constant	ms	1.83	1.84	1.82	1.32	1.35	1.26
Thermal Resistance <sup>(1)</sup>	°C/W	1.09			0.75		
Terminal Resistance (±12%)	Ohm	0.06	0.19	0.71	0.03	0.11	0.48
Terminal Inductance (±30%)	mH	0.29	1.00	3.72	0.15	0.58	2.76
Motor Weight (±8%)	lb	11.8	11.8	11.7	18.1	17.7	17.8
	kg	5.34	5.33	5.29	8.19	8.05	8.08

Model No.		QB05602			QB05603		
Winding Voltage	V	40	130	300	40	130	300
Stall Torque (continuous) <sup>(1)</sup>	oz-in	1675	1704	1634	2058	2057	2130
	Nm	11.8	12.0	11.5	14.5	14.5	15.0
Rated Power <sup>(1)</sup>	W	1880	2132	2042	2256	2432	2551
Rated Torque <sup>(1)</sup>	oz-in	1911	2466	2590	1939	2318	2372
	Nm	9.4	8.3	7.5	11.1	10.0	10.3
Rated Speed	RPM	2400	3550	5550	1700	2400	5150
Peak Torque	oz-in	12730	12764	12790	15874	15867	15842
	Nm	89.9	90.1	90.3	112.1	112.0	111.9
Rated Phase Current	A	71.2	28.0	12.8	86.6	29.8	15.7
Peak Current	A	502	266	133	617	288	149
Torque Constant (±10%)	oz-in/A	25.3	48.0	96.2	25.7	55.1	106.4
	Nm/A	0.179	0.339	0.679	0.182	0.389	0.751
Voltage Constant (±10%)	V/kRPM	18.7	35.5	71.1	19.0	40.7	78.7
	V/rad/s	0.179	0.339	0.679	0.182	0.389	0.751
Cogging Torque (max.)	oz-in	27.1			35.0		
	Nm	0.191			0.247		
Rotor Inertia	oz-in-s <sup>2</sup>	0.23			0.31		
	kg-m <sup>2</sup>	1.66E-03			2.17E-03		
Motor Constant	oz-in/√W	165	168	161	190	190	196
	Nm/√W	1.16	1.19	1.14	1.34	1.34	1.39
Elect. Time Constant	ms	6.82	7.06	6.48	6.96	6.97	7.48
Mech. Time Constant	ms	1.12	1.08	1.17	1.12	1.12	1.04
Thermal Resistance <sup>(1)</sup>	°C/W	0.60			0.52		
Terminal Resistance (±12%)	Ohm	0.02	0.08	0.36	0.02	0.08	0.29
Terminal Inductance (±30%)	mH	0.16	0.57	2.30	0.13	0.59	2.20
Motor Weight (±8%)	lb	24	24	23.7	30	29.8	29.6
	kg	10.9	10.9	10.8	13.6	13.5	13.4

(1) Motor mounted to 152 mm sq. x 6.35 mm (6 in. sq x 0.25 in.) aluminum plate in still air; maximum operating temperature (ambient + rise) is 130 °C.

(2) Storage temperature range is -55 to 150 °C.

# Brushless Servo Motors

## Quantum NEMA 56 Series Housed Brushless Servo Motors

### PERFORMANCE

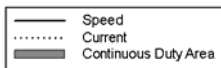
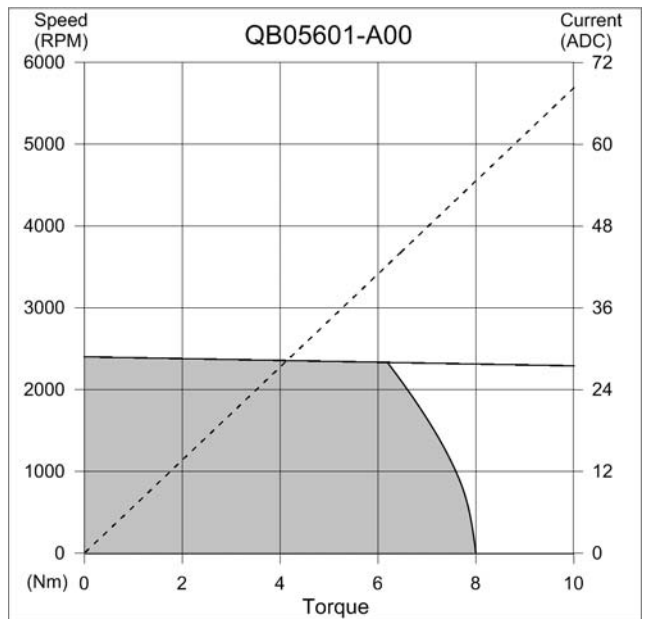
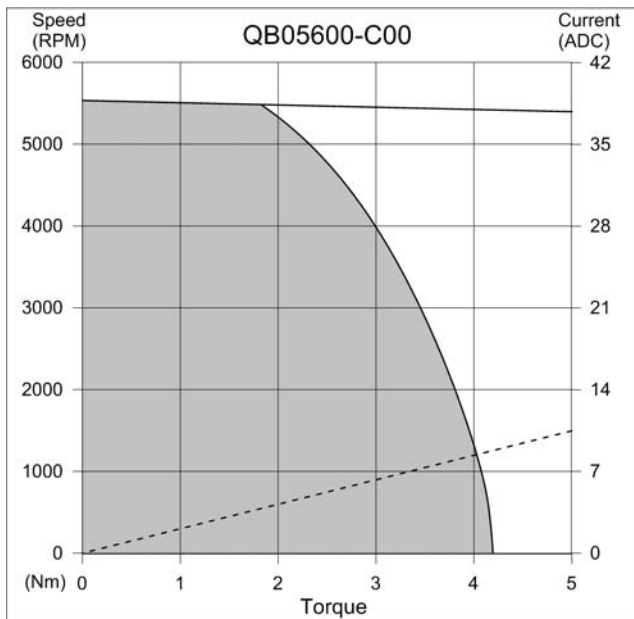
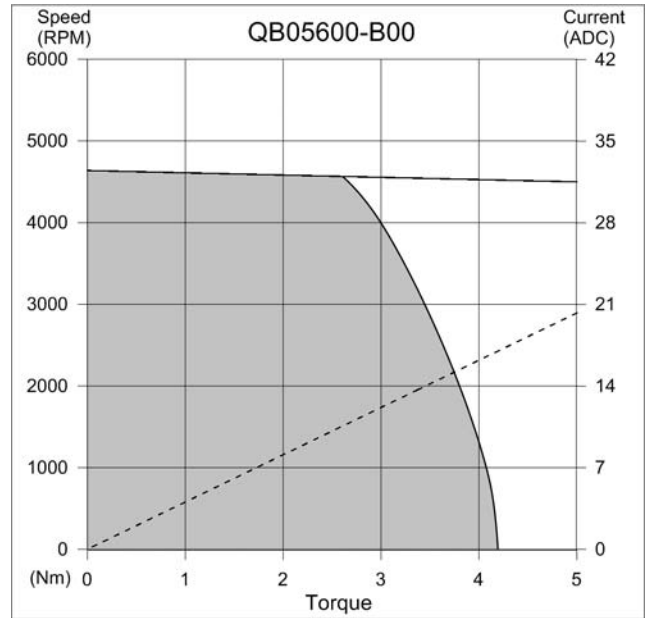
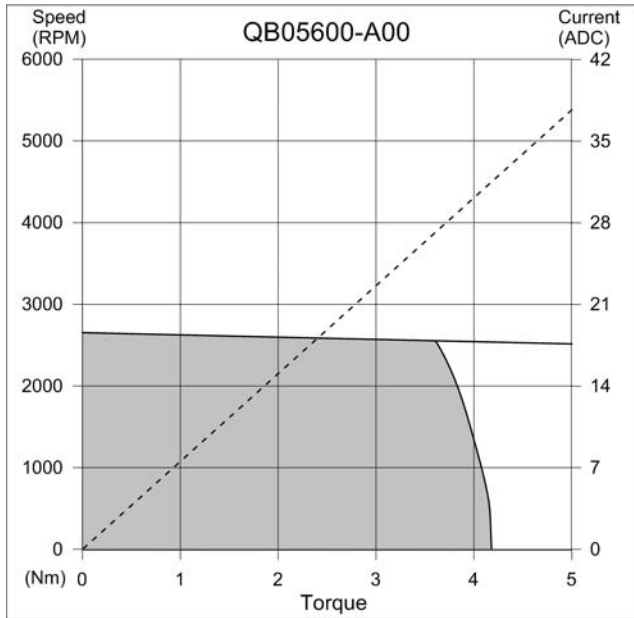

# Brushless Servo Motors

## Quantum NEMA 56 Series Housed Brushless Servo Motors

### PERFORMANCE

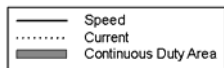
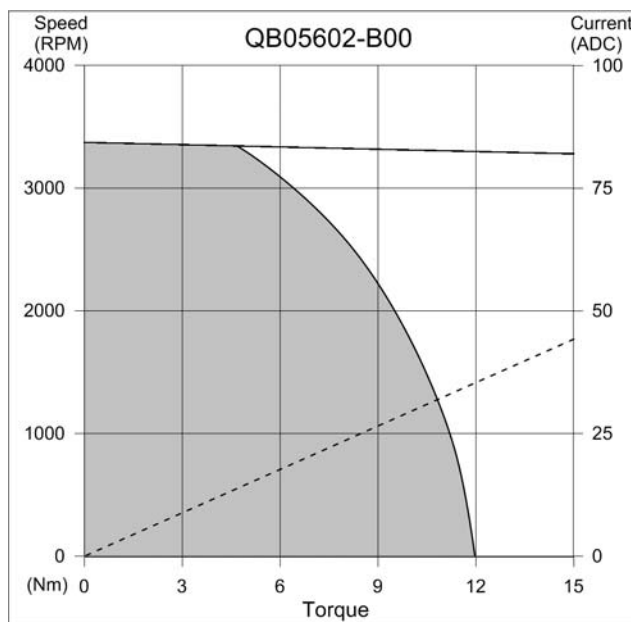
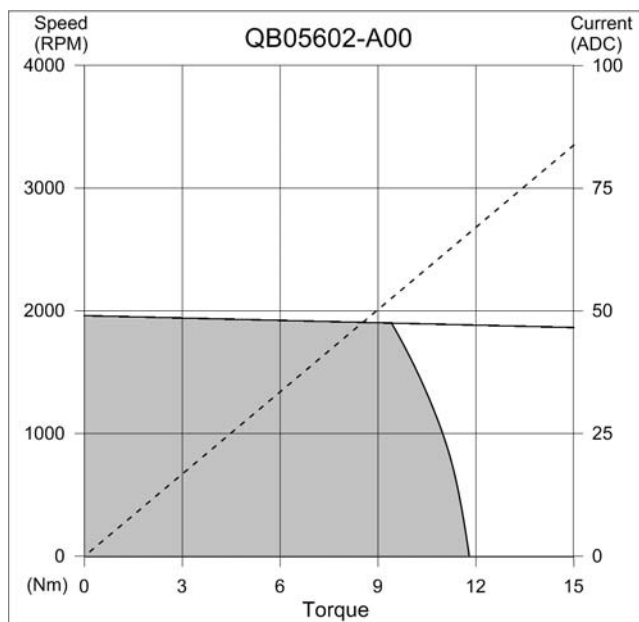
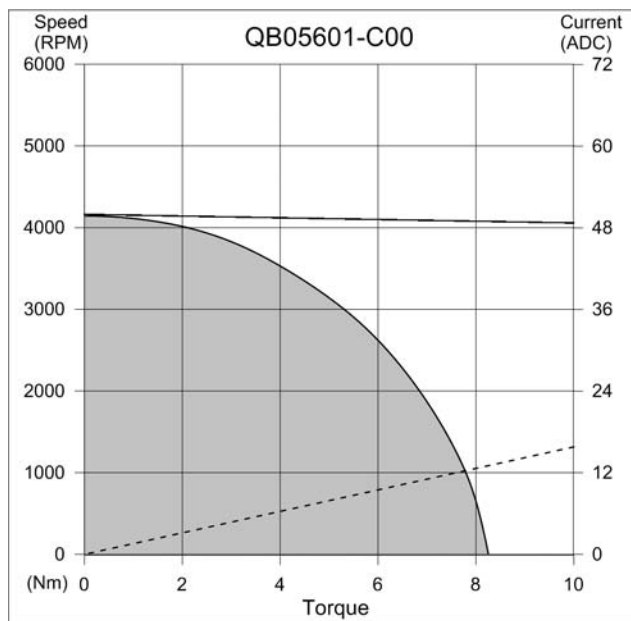
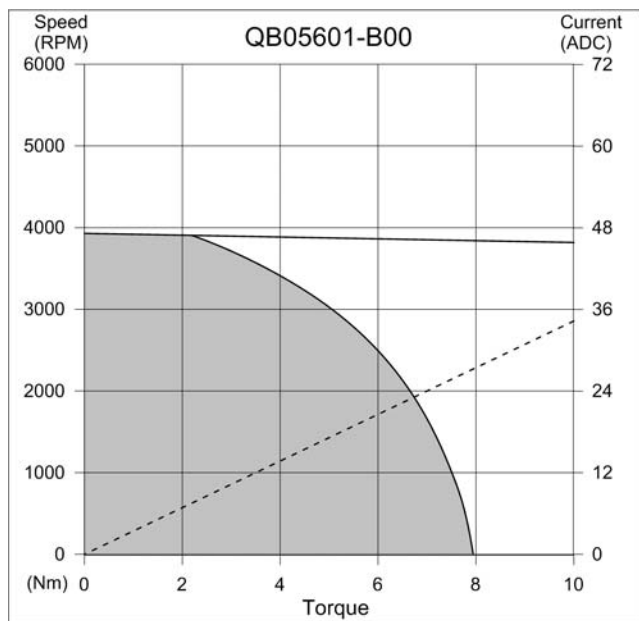

# Brushless Servo Motors

## Quantum NEMA 56 Series Housed Brushless Servo Motors

### PERFORMANCE

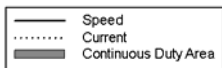
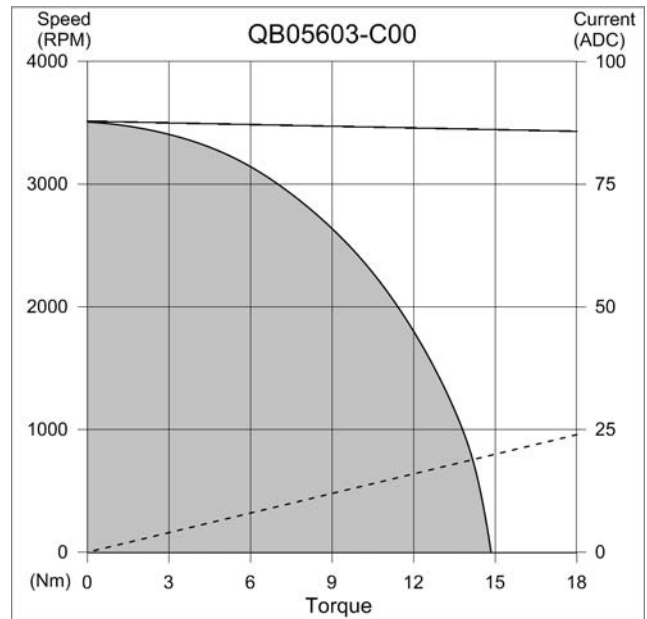
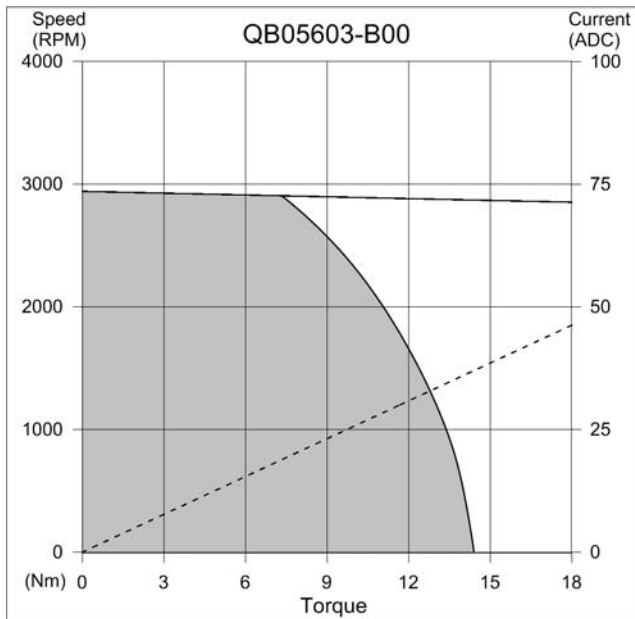
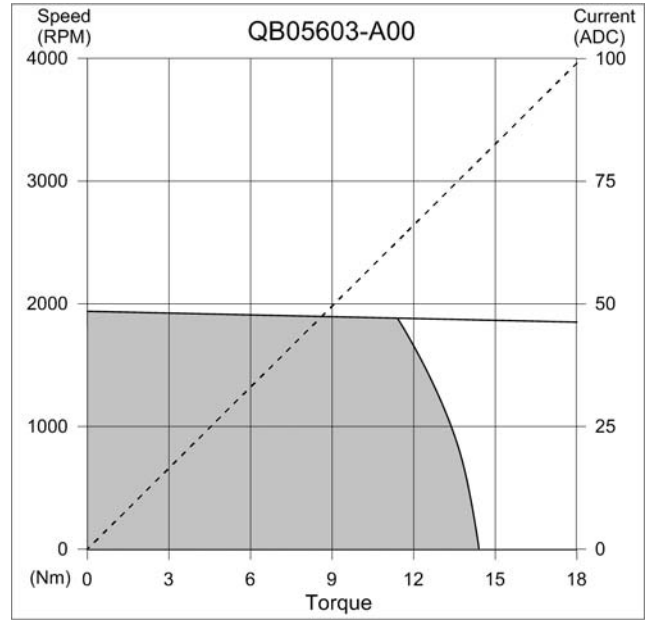
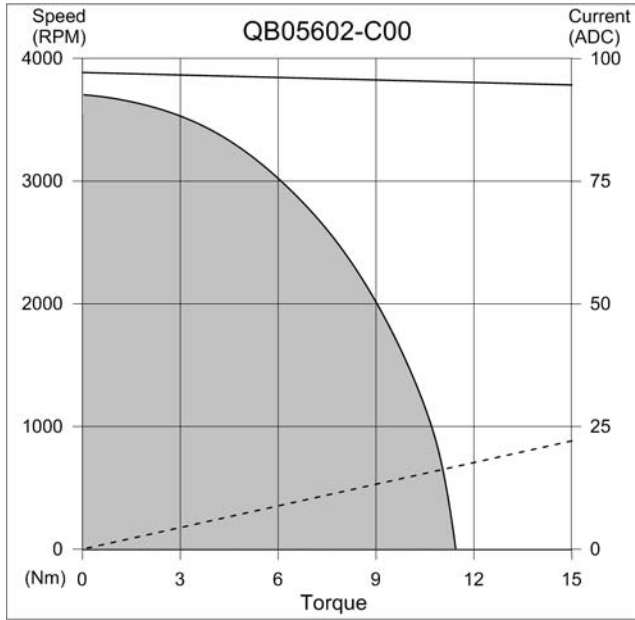

# Brushless Servo Motors

## Quantum NEMA 56 Series Brushless Servo Motors

### MODEL NUMBERING

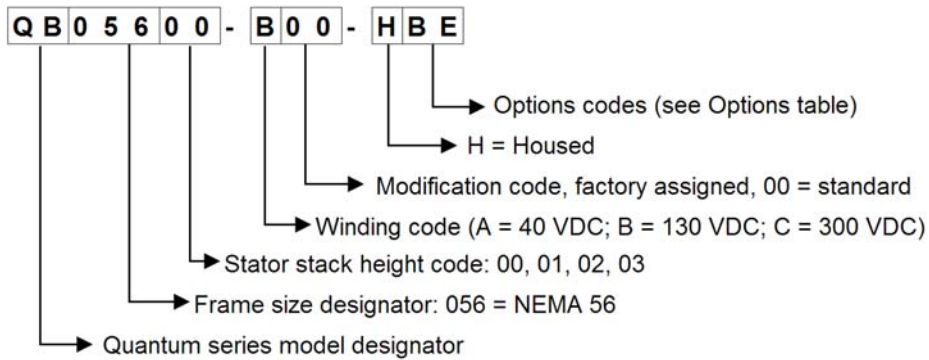

Options
E = Encoder
B = Holding brake
C = Motor connector
G = Gearbox
I = IP65 rating (IP44 std.)
P = Ruggedized housing
R = Resolver