

- ▶ **For applications with Safety Integrated Level or Performance Level requirements**
- ▶ **Up to 1000 Bar pressure range**
- ▶ **High strength, rugged stainless steel design**
- ▶ **With EC79 and EC406 approval for use with Hydrogen**



The SMO31H2-PLD is a version of the SMO31H2 Series intended for hydrogenic applications with safety integrated level or performance level requirements. It is a high quality all stainless steel pressure transducer for use around the measurement, production, storage and transportation of hydrogen in many industries.

The SMO series sensor has well proven use for high accuracy pressure sensing in automotive and industrial equipment amongst others, and

now offers ECU and other safety controlled applications compliance with DIN EN ISO 13849-1 and IEC 61508 and several other recognised safety accreditations.

The electronics in the SMO31H2-PLD are fully enclosed in a high-strength stainless steel housing with IP67 protection as standard and up to IP69K on request. Shock and vibration and other environmental performance specifications are more than consistent with the high reliability and long life offered by these premium range sensors.

Performance			Mechanics	
Accuracy @ RT	% of the range (gauge and vacuum sensors) < 0.5 BFSL ≤ 0.125	(incl. nonlinearity, hysteresis, repeatability, zero-offset and final offset acc. to IEC 61298-2)	Material	stainless steel
Non-linearity	% of the range ≤ 0.30		Pressure port	see select table
Repeatability	% of the range ≤ 0.20		Electrical connection	see select table
Stability/year	% of the range ≤ 0.20		Weight	ca. 60 g
Response time	(10..90%) t(ms)1		Environment	
Overrange pressure	up to 2x rated pressure		Temperature [°C]:	
Burst pressure	up to 5x rated pressure		Measuring medium	-40...125
Pressure cycles	> 10 million		Ambience	-40...105
			Storage	-40...125
			Compensated range	-20...85
Electronics			Temperature coefficient within the compensated range:	
Output -> Supply	4 - 20mA -> 10 - 32 VDC		Mean TC offset	% of the range ≤ 0,15 / 10K
Output impedance	$< \frac{U_{-10V}}{20mA}$		Mean TC range	% of the range ≤ 0,15 / 10K
Current consumption	< 10 mA		Shock	1000 G, 11 msec., 1/2 Sine
Reverse voltage protection	Yes		Vibration	25 G peak, 20 to 2000 Hz
			Sealing	IP 67, optional IP69K

Wiring						
	Round connector M12x1 A	Output	PIN 1	PIN 2	PIN 3	PIN 4
		4 - 20mA	+ Supply	N/A	- Current output	N/A
	Packard Metripac	Output	PIN A	PIN B	PIN C	-
		4 - 20mA	- Current output	+ Supply	N/A	-
	Cable assembly	Output	Red	Black	White	Green
		4 - 20mA	+ Supply	- Current output	N/A	-

# PRESSURE SENSOR - SMO31H2 - PLD



## Dimensions in mm

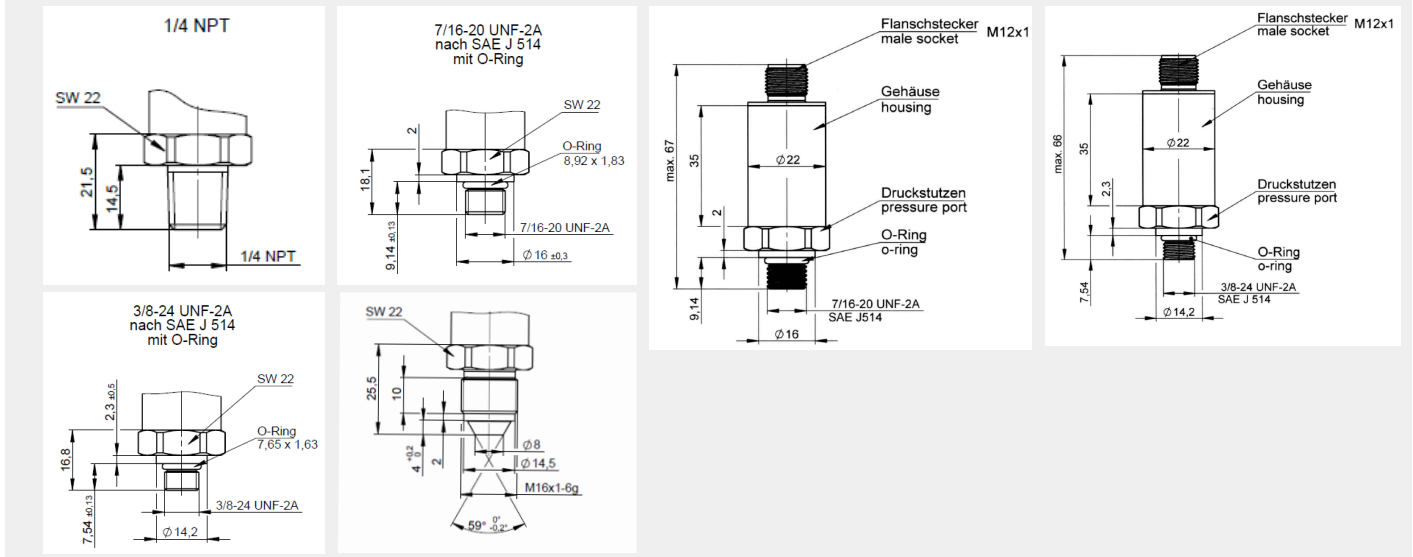

## Ordering information

(Please use the characters in the chart below to construct your product code)

**Sample Code** SMO31H2 - B - 01000 - B - 2 - A



Port Configuration	Pressure Range	Pressure Unit	Output Signal	Electrical Interface
M16 - M16x1 male up to 1000 bar (EC79 is limited to 700 bar)	Please use code from table below	B - gauge pressure V - vacuum pressure	2 = 4...20mA	A - 600 mm cable C - Packard Metripac connector F - M12x1 Round connector
B - 1/4 NPT max. 500 bar				
D - 7/16" - 20 UNF 2A Male up to 1000 bar (EC79 bis limited to 700 bar)				
N - 3/8"-24 UNF2A up to 700 bar (EC79 is limited to 700 bar)				
Custom options available on request				

## Pressure Range

Bar	1.0	1.6	2.5	4	6	10	16	20	25	40	50	60	100	160	250	400	448	600	700	1000
Order Code	00100	00160	00250	00400	00600	01000	01600	02000	02500	04000	05000	06000	10000	16000	25000	40000	44800	60000	70000	100000

The SMO31H2 PLd series is backed by a 1 Year Warranty. The purchaser is responsible for compatibility of the media, functional adequacy and correct installation of the



## PRODUCT CONFIGURATION

Product series: **SMO**  
Output Signal configuration: **18.0**

**SIL2**

## PERFORMANCE LEVEL INFORMATION

The sensor enables and EC-controlled safety system to perform as follows.  
These values have been calculated in accordance to

- [1] DIN EN ISO 13849-1
- [2] EN61508-6
- [3] IEC-TR62380
- [4] EPB-000110 & EPB-000206
- [5] FSM ZSC31050 Rev. 1.00 / April 2015

### Output Signal Safety Limits / diagnostic range:

The electronic circuitry and signal conditioner are providing defined safety limits for the output signal. These limits must be considered in the System ECU to enable the system to go into a safe state upon detecting these.

The *low* diagnostic range is **<3,85mA**

The *high* diagnostic range is **>22mA**

Depending on the detected failure, the output signal will go *below* or *above* these limits.

### Detected internal failures:

The following internal failures are detected by the signal conditioner and will actively lead to an output signal *below* or *above* the defined safety limits

- |  |                |                    |
|--|----------------|--------------------|
| - Broken bond wires (connections to the sensing element, in operation)   | <b>RESULT:</b> | <b>&gt;22mA</b>    |
| - Broken bond wires (connection to the sensing element, before power on) | <b>RESULT:</b> | <b>&lt; 3,85mA</b> |
| - Internal EEPROM errors caused by CRC                                   | <b>RESULT:</b> | <b>&lt; 3,85mA</b> |
| - Internal Watchdog (will trigger for different internal failures)       | <b>RESULT:</b> | <b>&lt; 3,85mA</b> |

### Startup time / power on:

- Startup time / power on = **max 40 ms**

During the defined startup period the output signal may vary between the diagnostic ranges.

The Signal must not be used in the ECU to determine sensor or system status.



## MTTFd Values / Performance Level:

The following performance level values have been determined (ref [4] and [5])

- MTTFd	= <b>228(100*) years</b>
- Failure Rate ( $\lambda F$ )	= <b>0,832310 10<sup>-6</sup> H<sup>-1</sup></b>
- DC (diagnostic coverage, dangerous failures)	= <b>72,17% (considered low)</b>
- CCF (common cause failures)	= <b>65% („use of proven component“ [5])</b>
- PERFORMANCE LEVEL	= <b>d, for a category 2 system, acc. Table K1 of [1]</b>

*\*According to [1] the  $MTTF_d$  is limited to 100 years.*

The following values are not used for performance level rating, but may be used for system evaluation.

- PFH	= <b>1,392* 10<sup>-7</sup>H<sup>-1</sup></b>
- SFF	= <b>83,27%</b>

The hardware architecture is defined as: 1001

Considered mission profile for failure rate calculation: *Automotive, Motor control cycling of [3]*